

Energy Storage Product Catalogue and Selection Guide

Roadmap

PRODUCT ROADMAP

MEDIUM POWER PRODUCT ROADMAP

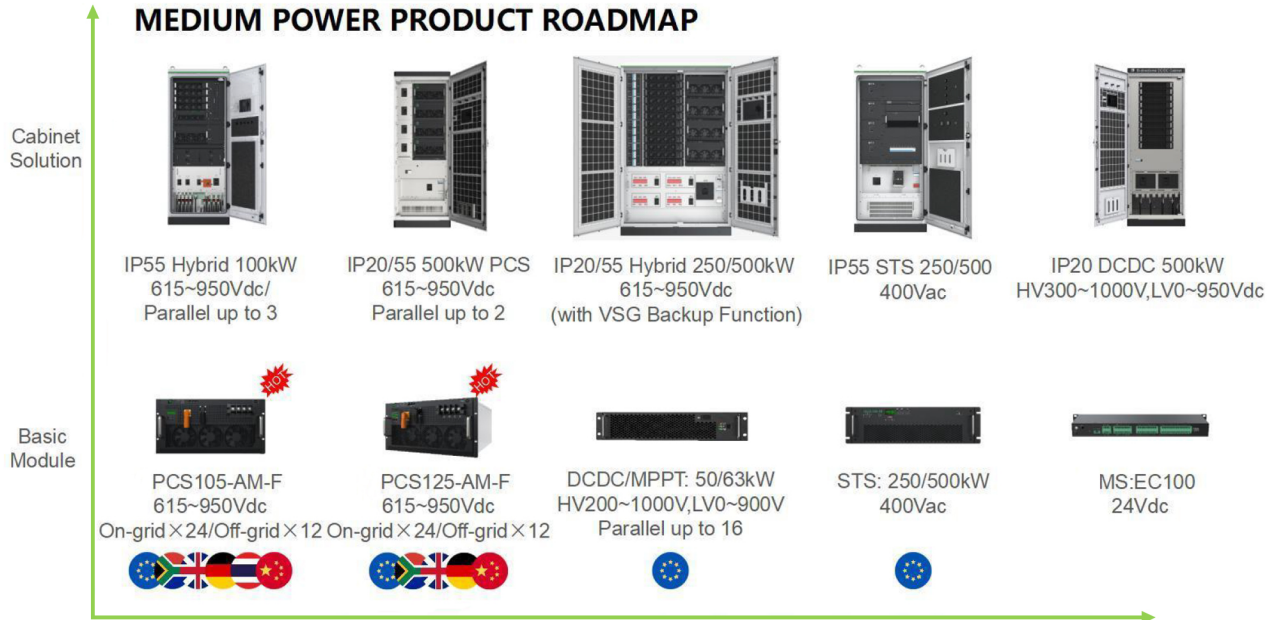

PRODUCT ROADMAP

HYBRID INVERTER ROADMAP

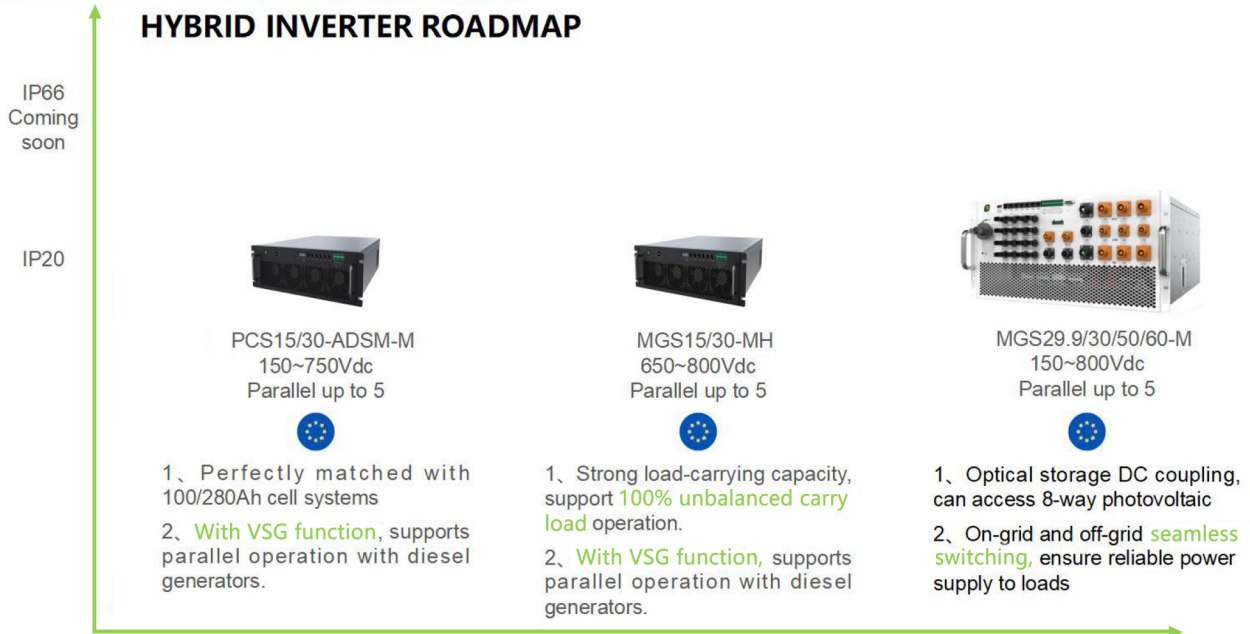

Roadmap

PRODUCT ROADMAP

HIGH VOLTAGE ROADMAP



PCS 215-AM
1000~1500Vdc
AC 400V/690V/800V



Basic Module



PGS1250/2000-AS
1000~1500Vdc
Parallel up to 2



Cabinet Solution



PCS2500/5000-AF
1000~1500Vdc



System Solution

PRODUCT ROADMAP

NEW COMING 135kW IP65 PCS

IP65 PCS135-EU/US

615~1000Vdc
Parallel up to 12

Efficient and Stable

- 1、 **Three-level topology**, high conversion efficiency, good power quality
- 2、 Device derating design, **good stability**, long equipment life

String Management

- 1、 **Cluster-level battery management**, cluster-level battery optimization
- 2、 **Longer system life**, highly competitive leveled cost of energy (LCOE)

Basic
Module



Flexibe Deployment

- 1、 Modular design, **smooth expansion**, strong scalability
- 2、 Support multi-machine parallel, can be **extended to MW level**

Grid Friendly

- 1、 Support **ms-level scheduling response**, active grid-forming
- 2、 Support **VSG grid-forming**, hybrid operation with diesel generator, and weak grid support

Catalogue

Medium Power 01 ● PCS

PCS105-AM(-F)

PCS125-AM(-F)

PCS135-AM

PCS135-EU/US

PCS500-AS

DCDC

DCS50/63-M-MH

DCS500-S-M

STS

STS250/500-M

STS250-S

STS500-S

EMS

C 100

Hybrid Inverter 02 ● Hybrid module

PCS15/30-ADSM-M

MGS15/30-MH

MGS29.9/30/50/60-M

Hybrid cabinet

MGS100/125-M(H)(S)

MGS250-MH(S)

MGS500-MH(S)

High Voltage 03 ●

PCS215-AM(-HX)

PCS1250/1500-ASH

PCS2500/5000-AF

PCS105-AM(-F)



Efficient conversion

Three-level topology with high conversion efficiency

High dynamic response, ms-level full-load charging/discharging switching



Intelligent collaboration

VSG / PQ / VF multiple operation modes

Off-grid parallelism, black start function



Safe and reliable

String design, wide DC voltage range, supports multiple types of battery use

Seamless off-grid and on-grid switching, with STS to provide uninterruptible backup power supply



Grid friendly

LVRT, HVRT, active power management and 100% unbalanced load

Excellent grid adaptability (stable operation under $THDu \leq 20\%$ operating conditions)

Typical Application

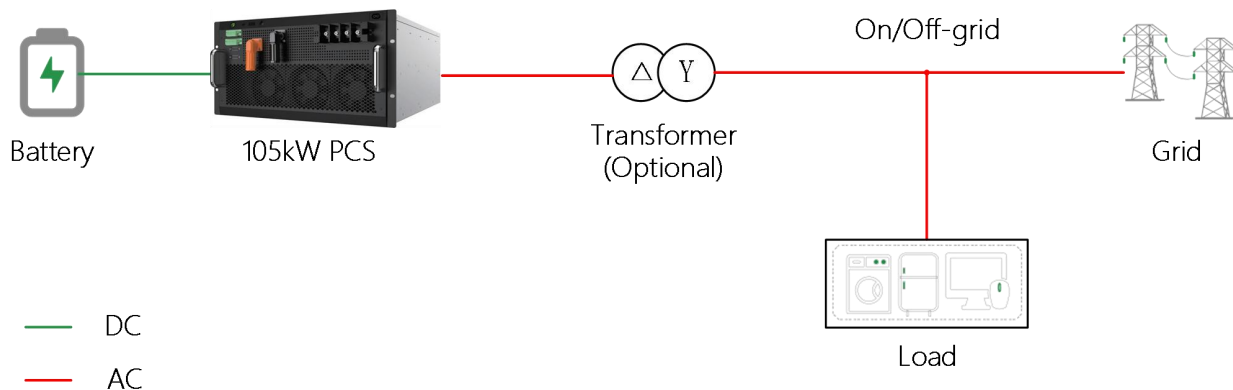

Technical Parameters

Spec.	PCS105-AM(-F)
DC side	
Operating voltage range	615 V ~ 950 V / 650 V ~ 950 V
Max. current	170 A
AC side	
Rated voltage	230 V / 400 V
Voltage range	±15%
Rated frequency	50 / 60 Hz
Wiring method	Three-phase Three-wire / Three-phase Four-wire
Maintenance method	Front side maintenance / Rear side maintenance
Rated power	105 kW
Max. power	115.5 kW
Max. current	167 A
Power factor	0.99 / -1~1
Current distortion rate	< 3% (@rated power)
DC component	< 0.5%
Overload capacity	110% long term
Max. efficiency	98.5%
General parameters	
Dimension (W × H × D)	500 × 270 × 670 mm
	440 × 255 × 620 mm (*)
Weight	66.5 kg
	59 kg (*)
Altitude	4000 m (derate above 2000 m)
Operating temperature	-30 °C~55 °C (derate above 45 °C)
Humidity	0% RH~95% RH, non-condensing
Cooling method	Intelligent air cooling
IP rating	IP20
Communication	CAN / RS485 / Ethernet
Storage temperature	-45 °C~70 °C

* Indicates the size / weight of the rear side maintenance mode

PCS125-AM(-F)



Low cost and high efficiency

Perfect match for 280 / 314 / 320Ah battery cells
High conversion efficiency with robust off-grid load capability

Intelligent control

High-efficiency intelligent speed control fan for better heat dissipation
Intelligent control with single-phase power regulation capability

Efficient and flexible

Compatible with three-phase three-wire/four-wire systems, supports 100% unbalanced load operation
Modular design, minimal installation, minimalist operation and maintenance

Intelligent and friendly

Supports EMS, BMS system linkage and active power quality management functions
Superior grid compatibility (THDi < 2% under THDu ≤ 20% operating conditions)

Typical Application

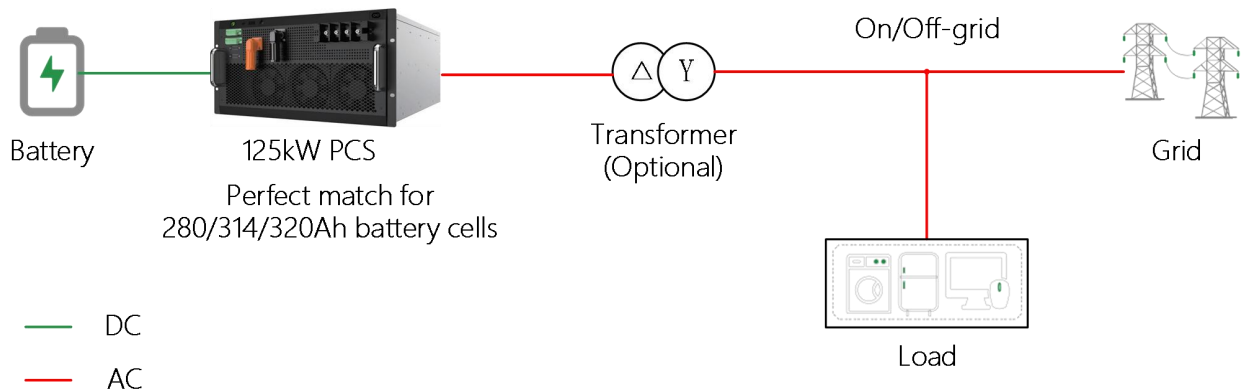

Technical Parameters

Spec.	PCS125-AM(-F)
DC side	
Operating voltage range	615 V~950 V / 650 V~950 V
Max. current	203 A
AC side	
Rated voltage	230V/400 V
Voltage range	±15%
Rated frequency	50 / 60 Hz
Wiring method	Three-phase Three-wire / Three-phase Four-wire
Maintenance method	Front side maintenance / Rear side maintenance
Rated power	125 kW
Max. power	137.5 kW
Max. current	200 A
Power factor	0.99 / -1~1
Current distortion rate	<2% (@rated power)
DC component	<0.5%
Overload capacity	110% long term
Max. efficiency	≥98.5%
General parameters	
Dimension (W × H × D)	Model A: 520 × 232 × 785mm; Model B: 500×270×670mm
	Model A: 520 × 232 × 725mm; Model B: 440×255×620mm (*)
Weight	Model A: 66.5kg/Model B: 66.5kg
	Model A: 64.5kg/Model B: 59kg (*)
Altitude	4000 m (derate above 2000 m)
Operating temperature	-30 °C~55 °C (derate above 45 °C)
Humidity	0% RH~95% RH, non-condensing
Cooling method	Intelligent air cooling
IP rating	IP20
Communication	CAN / RS485 / Ethernet

*Model A: Standard version; Model B: Size-optimized variant compatible with 105kW PCS module

*Indicates the size / weight of the rear side maintenance mode

PCS135-AM



Reduce cost and increase efficiency

High dynamic response, ms-level full load charge and discharge switching

High conversion efficiency, strong off-grid load carrying capacity

Intelligent control

High-efficiency intelligent speed control fan for better heat dissipation

Intelligent control, single-phase power adjustment

High efficiency and flexibility

Three-phase three-wire/four-wire compatible, support 100% unbalanced load

Modular design, minimal installation, minimal operation and maintenance

Intelligent and friendly

Support EMS, BMS system linkage and active power management function

Extreme grid adaptability

Electrical Schematic Diagram

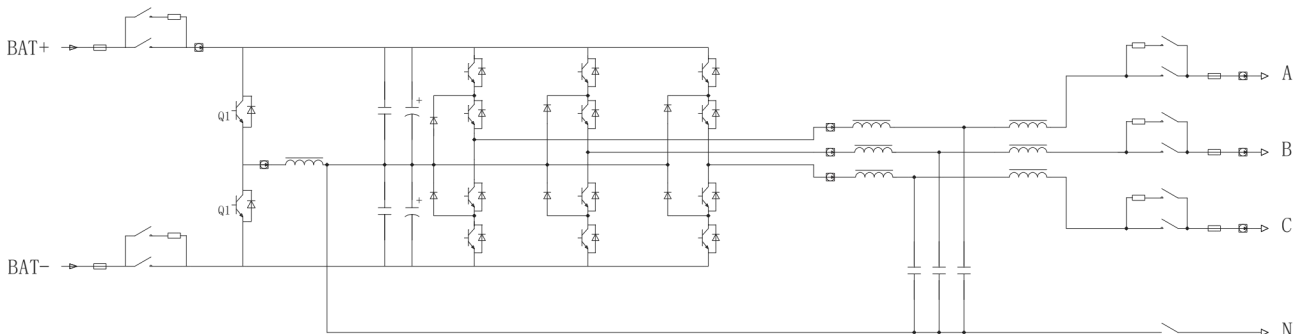

Technical Parameters

Spec.	PCS135-AM
DC side	
Operating voltage range	615V~1000V
Full load voltage range	680V~1000V
Maximum current	218A
Maximum charge/discharge power	148.5 kW
AC side	
Rated voltage	400V
Rated voltage range	- 15% ~ + 15%
Frequency range	50/60Hz
Wiring method	Three phase three wire/three phase four wire
Rated power	135kW
Maximum power	148.5 kW
Rated current	195A
Maximum current	215A
Power factor	0.99 /-1~1
Current distortion ratio	< 3% (rated power)
Overload capacity	110% 10min , 125% 1min
Maximum efficiency	98.5%
General parameters	
Dimensions (width x height x depth)	440 × 255 × 650mm
weight	62kg
Altitude	4000m (> 2000m derated use)
Operating temperature	-30 ° C to 55 ° C (>45°C derated use)
Storage temperature	- 45 °C ~ 70 °C
Humidity	0%RH to 95%RH, no condensation
Cooling method	Intelligent air cooling
IP level	IP20
Means of communication	CAN/RS485/ Ethernet
Communication protocol	CAN2.0B, Modbus TCP/RTU

*Product parameters and specifications are subject to change without prior notice.

PCS135-EU/US



Efficient and stable

Three-level topology, high conversion efficiency, good power quality

Device derating design, good stability, long equipment life

Flexible deployment

Modular design, smooth expansion, strong scalability

Support multi-machine parallel, can be extended to MW level

String management

Cluster-level battery management, cluster-level battery optimization

Longer system life, highly competitive leveled cost of energy (LCOE)

Grid friendly

Support ms-level scheduling response, active grid-forming

Supports VSG grid-forming, hybrid operation with diesel generator, and weak grid support

Technical Parameters

Spec.	PCS135-EU	PCS135-US
DC side		
Working voltage range	615V~1000V	AC 480V: 720V~1000V (3P3W) /835V~1000V (3P4W) AC 208V: 390V~1000V (full load for 390~750V) AC 120V/240V: 390V~1000V (full load for 390~750V)
Max. current	AC 400/480/208V 249A AC 120V/240V 166A	
Max. charge/discharge power	AC 400/480V 153kW	AC 208V 79kW AC 120V/240V 51kW
AC side		
Rated voltage	400V	480V/208V(3P3W 3P4W)/120V/240V split phase
Voltage range	-15%~+15%	
Frequency	On-grid mode:50Hz±5Hz VSG with diesel generator: 50Hz±15Hz	On-grid mode: 60Hz±5Hz VSG with diesel generator: 60Hz±15Hz
Wiring method	3P3W/3P4W	3P3W/3P4W (DC-DC can be optional)

Rated power	135kW	AC 480V: 135kW; AC 208V: 70kW; AC 120V/240V: 45kW
Max. power	149kW	AC 480V: 149kW; AC 208V: 77kW; AC 120V/240V: 50kW
Rated current		AC 400/480/208V 195A AC 120V/240V 130A
Max. current		AC 400/480/208V 215A AC 120V/240V 143A
Power factor		0.99 /-1~1
Current distortion rate		<3% (rated power)
Overload capacity		110% long term, 125% 1min, 130% 10s, 150% 200ms
Max. efficiency		98.8%

General parameters

Dimensions (W × H × D)	275 × 845 × 910mm
Weight	105kg
Altitude	4000m (> 3000m derated use)
Working temperature	-30°C ~60°C (>50°C derated use)
Storage temperature	-40°C ~70°C
Humidity	0%RH ~ 100%RH, no condensation
Cooling method	Intelligent air cooling
Ingress protection rating	IP65
Communication method	CAN/RS485/Ethernet/4G
Communication protocol	IEC61850, CAN2.0B, Modbus TCP/RTU, DL/T860

*Product parameters and specifications are subject to change without prior notice.

PCS500-AS



Configure flexibly

Supports 4 clusters of battery access to solve battery loop current
Pre-maintenance design for easy operation and maintenance



Efficient and stable

Three-level modular design, high efficiency
Each module operates independently



Grid friendly

LVRT and HVRT functions
Active and reactive power four-quadrant adjustment functions



Intelligent collaboration

VSG / PQ / VF multiple operation modes
Off-grid parallelism, black start function

Typical Application

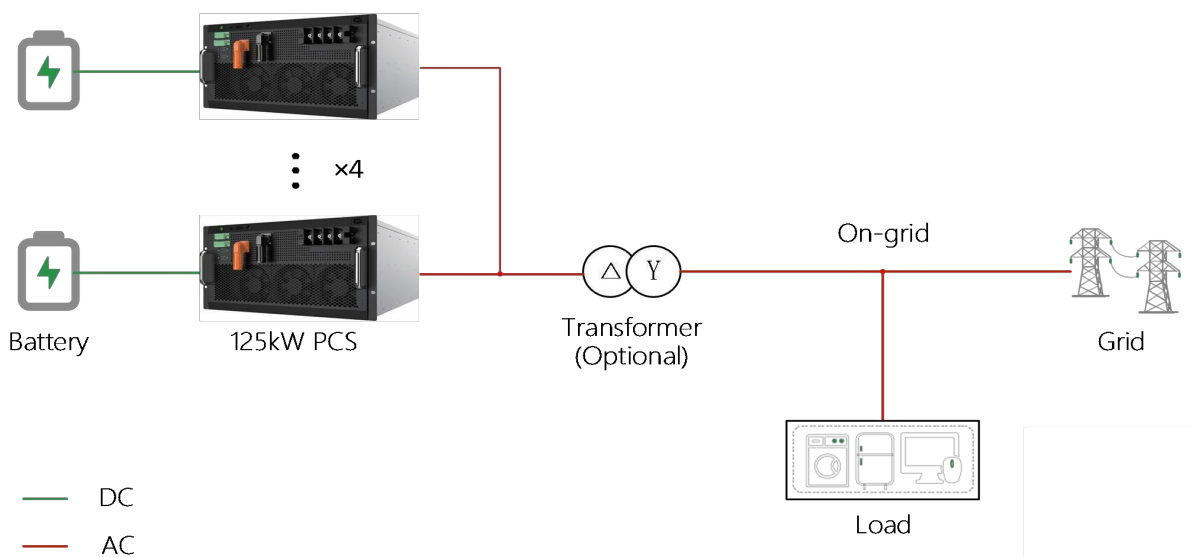

Technical Parameters

Spec.	PCS500-AS
DC side	
Operating voltage range	615 V ~ 950 V / 650 V ~ 950 V
Max. current	203 × 4 A
Number of DC inputs	4
AC side	
Rated voltage	400 V
Voltage range	±15%
Rated frequency	50 / 60 Hz
Wiring method	Three-phase Three-wire / Three-phase Four-wire
Rated power	500 kW
Max. power	550 kW
Max. current	200 × 4 A
Power factor	0.99 / -1~1
Current distortion rate	<2% (@rated power)
DC component	<0.5%
Overload capacity	110% long term
Max. efficiency	98.5%
General parameters	
Dimension (W × H × D)	1000 × 2160 × 1100 mm
Weight	<650 kg
Altitude	4000 m (derate above 2000m)
Operating temperature	-30 °C~55 °C (derate above 45°C)
Humidity	0% RH ~ 95% RH, non-condensing
Cooling method	Intelligent air cooling
IP rating	IP55
Communication	CAN / RS485 / Ethernet
Compliant certifications	GB/T 34120-2023, GB/T 34133-2023, IEC/EN 62477-1, IEC/EN 62116, IEC/EN 62109-1

*The EPCS500-AS energy storage cabinet in this manual use the typical solution of fully configured EPCS125-AM modules. For power levels below 500kW, please contact our technical engineers for more information.

DCS50/63-M-MH



Intelligent collaboration

- Support DC source input for batteries, PV, etc
- Low voltage side current 160A, support mainstream 280/314Ah cells
- Cluster-level battery management to address battery circulation current problems
- Supports constant voltage/constant current/constant power/boost/buck MPPT operation mode

Safe and reliable

- Perfect and reasonable EMC design
- Support multi-branch control, perfect fault protection function
- Insulation detection functions on both high and low voltage sides
- The DC side is equipped with a high-performance contactor for safety and reliability

Wide voltage range

- The low voltage side supports 0V pre-charging
- Wide voltage range operation

High efficiency and flexibility

- Module 2U highly extreme structural design for high power density
- Supports 16 parallel machines and automatic equalisation of flow, uneven flow <5%
- Maximum operating efficiency 99%

Typical Applications

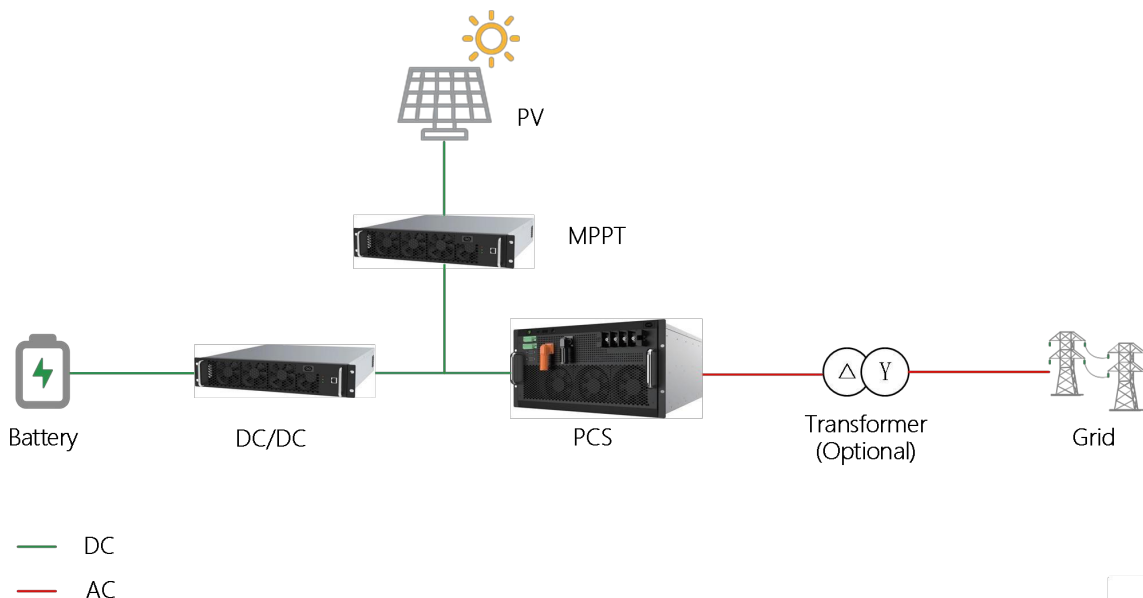

Technical Parameters

Spec.	DCS50-M-MH	DCS63-M-MH
Electrical parameters		
Rated power	50kW	63kW
Long-term overload power	55kW	70kW
High voltage side voltage	200V ~ 1000V	
High voltage side full-load voltage range	455V~1000V	573V~1000V
High voltage side maximum current	110A	
Low voltage side voltage	0V ~ 900V	
Low voltage side full-load voltage range	313V~900V	394V~900V
Low voltage side maximum current	160A	
Maximum efficiency	99%	
Operation mode	Constant voltage, bidirectional constant voltage, constant current, constant power, boost MPPT, buck MPPT	
Static voltage stability	± 1%	
Dynamic voltage stability	± 5%	
Static current stability	± 1%	
Dynamic current stability	± 3%	
Accessibility	0V pre-charge (the low side can start operating from 0V); The module supports three power inputs: the low-voltage side, the high-voltage side, and external 220V. Any input voltage exceeding 200V will power on	
Parallel operation	Supports parallel operation in all modes, with a maximum of 16 units in parallel	
Protection function	Fuse protection, overcurrent protection, over-temperature protection, low voltage side undervoltage and overvoltage protection, high voltage side undervoltage and overvoltage protection, overpower protection, low voltage side short circuit protection, reverse connection protection, anti-surge protection, insulation detection protection and temperature derating output, etc	
General parameters		
Dimensions (W × H × D)	440 × 88 × 620mm	
Weight	25kg	
Altitude	4000m (> 2000m derated use)	
Operating temperature	-30°C ~ 60°C (>45°C derated use)	
IP level	IP20	
Communication method	RS485/CAN/Modbus RTU	
Compliant with standards	IEC/EN 62477-1:2012, IEC/EN 62109-1:2010	
Power port	HV± on HV side, LV± on LV side	
Protection level	I	
Cooling method	Intelligent air cooling	

DCS500-S-M



Wide voltage range

The low voltage side supports 0V pre-charging
Wide voltage range operation



Efficient and flexible

Maximum operating efficiency of over 99%
Modular design, supports parallel operation
Cluster-level battery management to address battery cycling issues



Intelligent collaboration

Supports DC source inputs such as batteries, photovoltaics, etc.
Support constant voltage / constant current / constant power/boost/buck-MPPT operation mode



Safe and reliable

Perfect and reasonable EMC design
Support multi-branch control, perfect fault protection function

Typical Applications

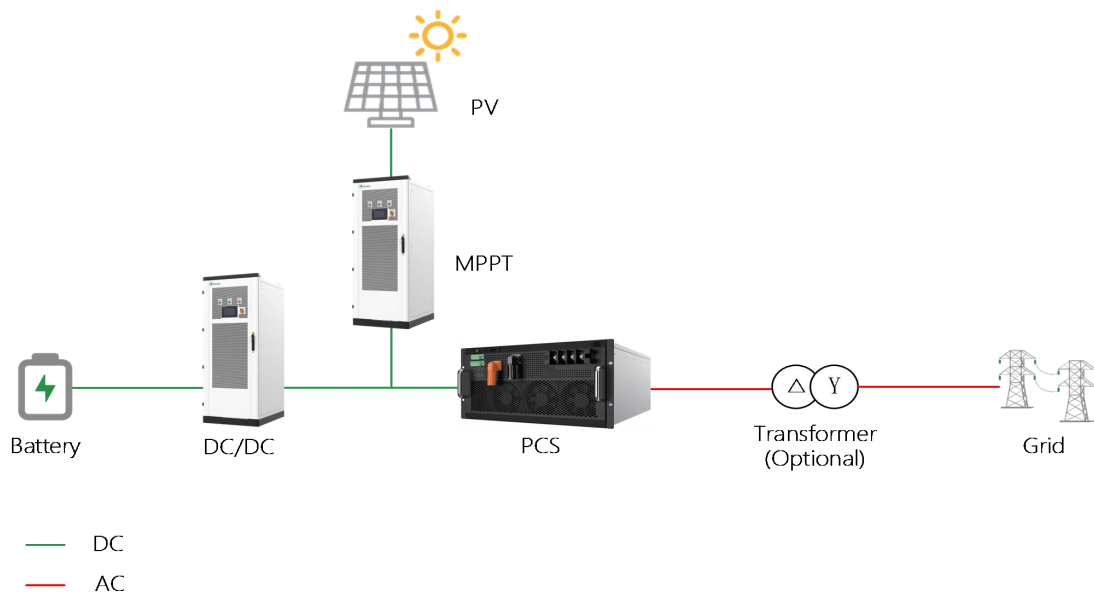

Technical Parameters

Spec.	DCS500-S-M
Electrical parameters	
Rated power	500 kW (*)
Voltage (HV side)	250 V ~ 1000 V
Max. current (HV side)	800 A
Voltage (LV side)	0 V ~ 900 V
Max. current (LV side)	1000 A
Max. efficiency	>99%
Operating mode	Constant voltage, bi-directional constant voltage, constant current, constant power, boost-MPPT, buck-MPPT
Auxiliary function	Low voltage side supports 0V pre-charging
Parallel operation	Supports all modes of multi-module parallel connection; supports all modes of multi-cabinet parallel connection
Protection functions	Reverse connection protection, short circuit protection, over-temperature protection, over-under-voltage protection, over-current protection, insulation detection
General parameters	
Dimension (W × H × D)	800 × 2160 × 800 mm
Weight	600 kg
Altitude	4000 m (derate above 2000m)
Operating temperature	-25 °C~55 °C (derate above 45 °C)
Operating humidity	0% RH~95% RH, non-condensing
Cooling method	Intelligent air cooling
IP rating	IP20
Communication	RS485
Isolation method	None
Monitor	7-inch touchscreen display
Compliant certifications	IEC/EN 62109-1, IEC/EN 62109-2

*For other power customization requirements, please contact our technical support engineers.

STS250/500-M



STS series of switching devices can realize the fast switching of parallel and off-grid status within 20ms. Under normal operating conditions, the static switch is closed; In the event of a utility interruption, the static switch is immediately disconnected and the energy storage system switches to off-grid operation mode, where the battery discharges to provide power to critical loads and ensures that the power from the storage system is not reversed to the grid.

Intelligent collaboration

Intelligent and fast separation of power grid and micro-grid, switching power supply loop (< 20ms) to achieve uninterrupted power supply of load.

Front - maintenance design for convenient operation and maintenance

Safe and reliable

Highly reliable backup design to ensure that important loads are not interrupted

Intelligent operation with communication interfaces such as CAN and RS485

Typical Application

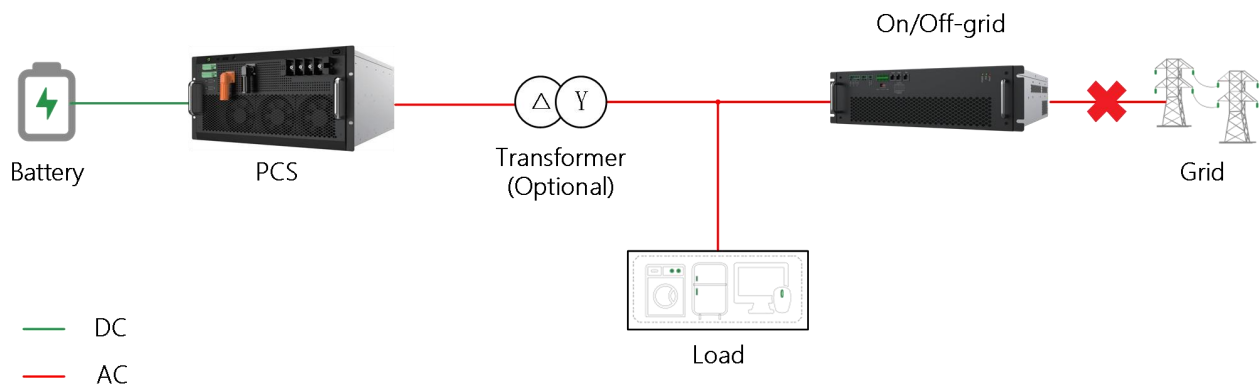

Technical Parameters

Spec.	STS250-M	STS500-M
Grid port power	250kVA	500kVA
Rated grid port current	361A	722A
Load side port power	250kVA	500kVA
Rated voltage	400V	
Grid side voltage range	400V±15%	
Rated frequency	50/60Hz	
On/off-grid switching time	<20ms	
Max. efficiency	>99.5%	
Auxiliary power source power	60W	100W
Communication		
Communication port	RS485	
Communication protocol	ModBus RTU	
General parameters		
Dimension (W × H × D)	440 × 130 × 520mm	440 × 200 × 500mm
Weight	22kg	39.6kg
Altitude	4000m (derate above 2000m: derate by 1% for every 100m increase in altitude)	
Operating temperature	-25°C~55°C (derate above45°C)	
Storage temperature	-45°C~70°C	
Humidity	0%RH ~ 95%RH, non-condensing	
Cooling method	Intelligent air cooling	
IP rating	IP20	
Power port	RST on the power grid side and UVW on the load side	
Wiring method	Three-phase Three-wire	
User interface	None	

*Product specifications are subject to periodic updates without prior notice.

STS250-S

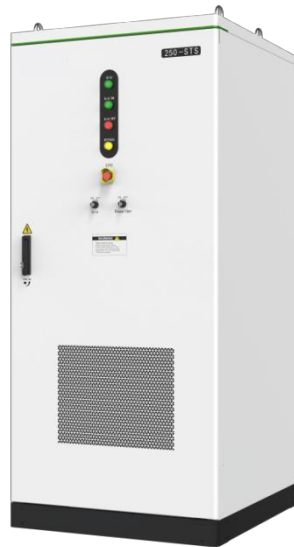

Automatic transfer

Automatic grid switching and synchronization
Compatible with VSG grid-forming switching and seamless conversion with diesel generators

Fast switching

Active switching cycle: 0 ms
Passive switching cycle: less than 20 ms

Convenient power distribution

Built-in UPS to ensure auxiliary power supply
Optional PV and diesel generator connection ports for flexible configuration.

Built-in optional EMS system

Intelligent collaborative scheduling for optimal power distribution in Solar-Storage-DG systems.
Access of various BMS systems

Internal Structure

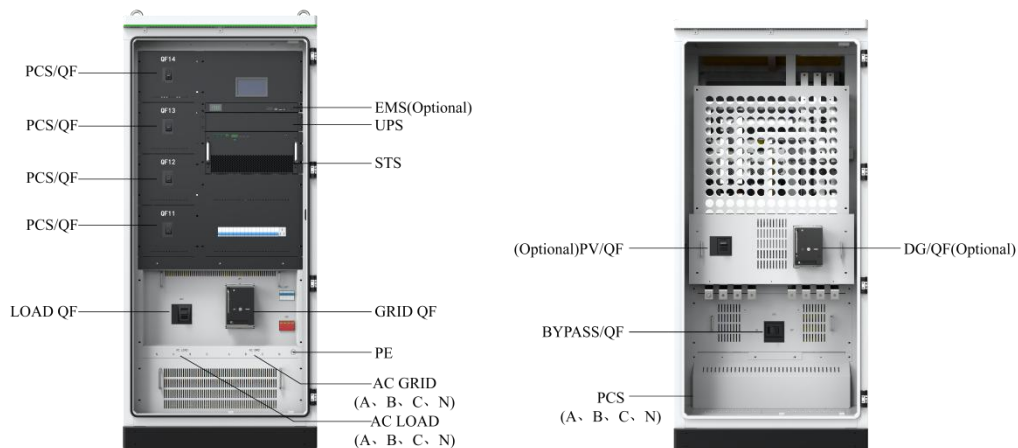

Technical Parameters

Specification	STS250-S
Grid-side parameters	
Grid voltage	400V, 3W+N+PE (±15%)
Rated AC power	250kW
Rated AC current	360A
Rated grid frequency	50/60 Hz±2.5 Hz
Required THDU	<10%
Parameters of load interface	
Grid voltage	400V, 3W+N+PE
Rated AC power	250kW
Rated AC current	360A
Rated grid frequency	50/60 Hz±2.5 Hz
Parameters of PCS interface	
Grid voltage	400V, 3W+N+PE
Rated AC power	250kW (125kW*2ports)
Rated AC current	360A
Rated grid frequency	50/60 Hz±2.5 Hz
Required THDU	<10%
Parameters of Optional Diesel Generator and PV Connection Ports	
Rated AC power	250kW (diesel input) / 250kW (PV input)
Rated AC current	360A (diesel input) / 360A (PV input)
System parameters	
Bypass function	Standard configuration
Switching cycle	<20 ms
Overload capacity	1.1x @ 1min
UPS power supply	1kVA/220VAC
Isolation mode	Non-isolated
Dimensions (W * H * D)	900*2000*1000mm
Weight	500 kg
Communication interface	RS485
Operating temperature	-25°C ~ 55°C
Altitude	4,000 m (> 2,000 m derated use)
Heat dissipation method	Intelligent air-cooling
Design life	20
IP grade	IP54

* Product parameters and specifications are updated irregularly without prior notice.

STS500-S

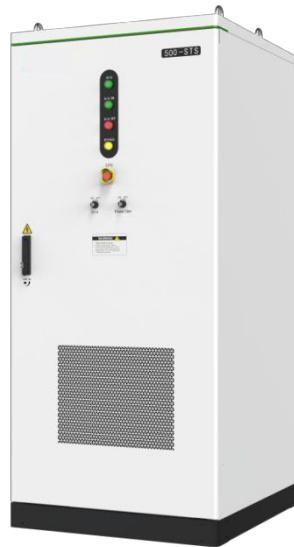

Automatic transfer

Automatic grid switching and synchronization
Compatible with VSG grid-forming switching and seamless conversion with diesel generators

Fast switching

Active switching cycle: 0 ms
Passive switching cycle: less than 20 ms

Convenient power distribution

Built-in UPS to ensure auxiliary power supply
Optional PV and diesel generator connection ports for flexible configuration.

Built-in optional EMS system

Intelligent collaborative scheduling for optimal power distribution in Solar-Storage-DG systems.
Access of various BMS systems

Internal Structure

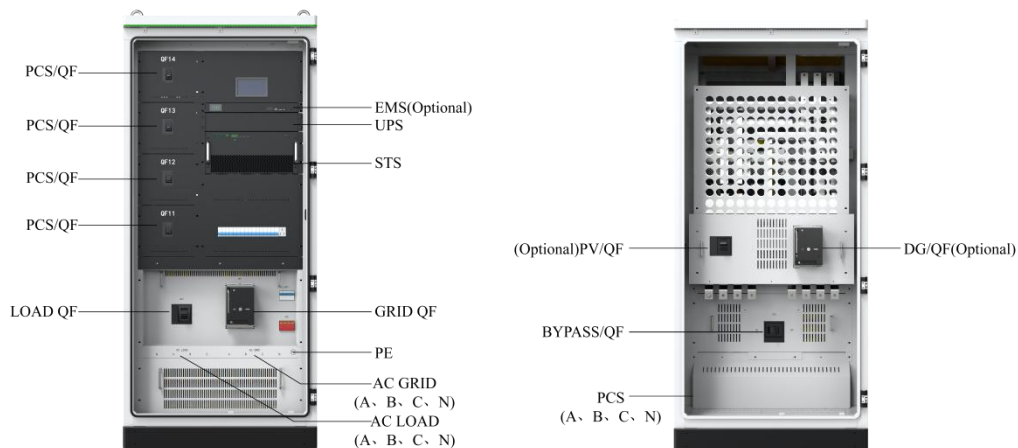

Technical Parameters

Specification	STS500-S
Grid-side parameters	
Grid voltage	400V, 3W+N+PE (±15%)
Rated AC power	500kW
Rated AC current	720A
Rated grid frequency	50/60 Hz±2.5 Hz
Required THDU	<10%
Parameters of load interface	
Grid voltage	400V, 3W+N+PE
Rated AC power	500kW
Rated AC current	720A
Rated grid frequency	50/60 Hz±2.5 Hz
Parameters of PCS interface	
Grid voltage	400V, 3W+N+PE
Rated AC power	500kW (125kW*4ports)
Rated AC current	720A
Rated grid frequency	50/60 Hz±2.5 Hz
Required THDU	<10%
Parameters of Optional Diesel Generator and PV Connection Ports	
Rated AC power	500kW (diesel input) / 500kW (PV input)
Rated AC current	720A (diesel input) / 720A (PV input)
System parameters	
Bypass function	Standard configuration
Switching cycle	<20 ms
Overload capacity	1.1x @ 1min
UPS power supply	1kVA/220VAC
Isolation mode	Non-isolated
Dimensions (W * H * D)	900*2000*1000mm
Weight	500 kg
Communication interface	RS485
Operating temperature	-25°C ~ 55°C
Altitude	4,000 m (> 2,000 m derated use)
Heat dissipation method	Intelligent air-cooling
Design life	20
IP grade	IP54

* Product parameters and specifications are updated irregularly without prior notice.

C 100



Cloud Edge Collaboration

Cloud-side integrated design, accurate local collection, centralized monitoring in the cloud



Intelligent Strategy

Peakshaving, demand control, pumping scheduling, flex-direct interconnections and co-controls



Data acquisition

Rich interfaces, highly integrated, widely interfaced with various protocols.



Wide range of applications

Covering a wide range of scenarios, including energy storage, photovoltaics, wind turbines and diesel generation



Configure flexibly

DI/DO/communication interface can be flexibly configured for different needs



Fast switching

Automatic and seamless switchover between on-grid and off-grid

Typical Application

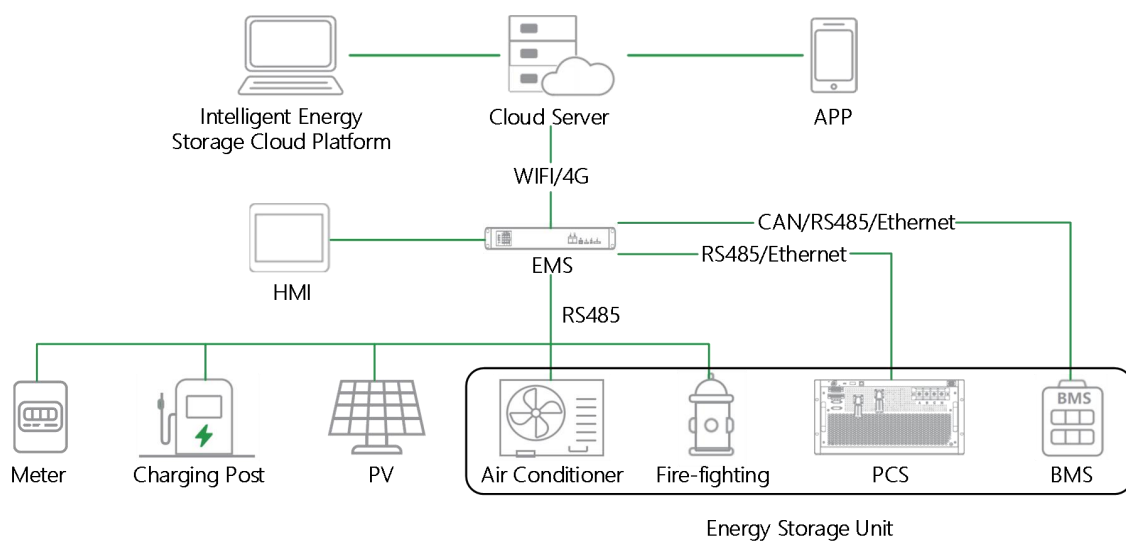

Technical Parameters

Project	Specification	Illustration
Control function	Dynamic voltage regulation, peak shaving and valley filling, demand control, dynamic capacity expansion	Can be customized according to demand
SD	SD card interface	Reserved
USB-HOST	U disk interface	For software upgrades
RST	Reset port	For local controller reset
Communication interface	2 Ethernet, 8 RS485, 2 CAN, 1 4G	
Communication protocol	Ethernet: Modbus TCP/ MQTT, etc. RS485: Modbus RTU; CAN: CAN2.0	Other protocols can be customized
Digital output (DO)	16 channels, support normally open / closed	Relay output, relay specification: 250Vac / 3A or 30Vdc / 3A
Digital input (DI)	16 channels	Supports passive dry contact input signals
Analog input	6 channels	Reserved
Indicator light	Power lights, running lights, warning lights, communication lights, etc.	
RF	Wireless antenna interface	Reserved
GPS	GPS antenna interface	Reserved
Power input	DC24V	Current < 2A
Operating temperature	-25 °C~60 °C	
Altitude	≤ 4000 m	
Ambient relative humidity	0% RH ~ 95% RH, non-condensing	
Monitor	10.1-inch display	For other display sizes, contact us
IP rating	IP20	
Weight	1.84 kg	
Dimension (W × H × D)	440 × 44 × 120 mm	
Installation method	Rack mounted	

PCS15/30-ADSM-M



Exquisite design

Stylish appearance, lightweight design, and easy and flexible operation

Rack - mount design, high space utilization rate, and low operating noise



Diverse adaptation

Wide voltage input range from 150V to 750V
Perfectly matched with 100/280Ah cell systems



Powerful performance

Strong load-carrying capacity, supporting 100% unbalanced load

Equipped with VSG function, supporting joint load-carrying with diesel generators



Grid friendly

Supporting parallel operation of 5 modules in on-grid or off-grid mode

Built in lightweight EMS, supporting application scenarios such as self-generation for self-consumption and micro-grids

Typical Application

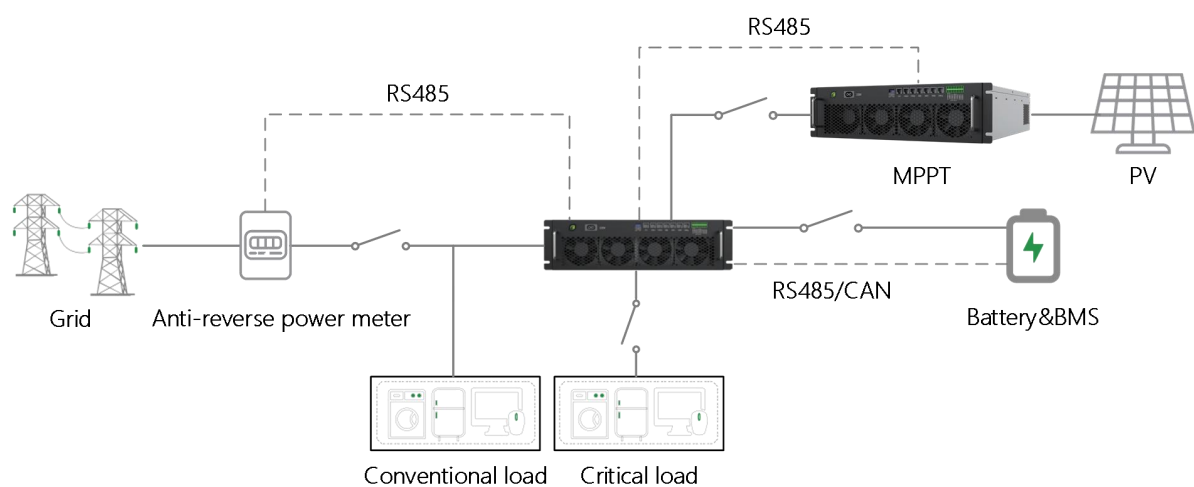

Technical Parameters

Spec.	PCS15-AM	PCS30-AM
DC side (Battery)		
Battery type	Lithium battery / Lead-acid battery	
Max. charge/discharge power	16.5kW	33kW
Operating voltage range	150V~750V	
Full-load voltage range	150V ~ 750V	214V ~ 750V
Max charge/discharge current	140A	
Number of battery branches	1	
AC side (Grid)		
Rated output power	15kVA	30kVA
Max. output power	16.5kVA	33kVA
Max. input power	33kVA	66kVA
Output wiring system	3W+PE/3W+N+PE	
Rated output voltage	400V (-15%~+15%)	
Rated frequency	50Hz	
Rated output current	21.7A	43.4A
Max. output current	23.9A	47.8A
Max. input current	47.8A	95.6A
Max. THDi	< 3%	
AC side (Load)		
Rated output power	15kVA	30kVA
Max. output power	16.5kVA	33kVA
Output wiring system	3W+PE/3W+N+PE	
Rated output voltage	400V (-15%~+15%)	
Rated frequency	50Hz	
Rated output current	21.7A	43.4A
Max. output current	23.9A	47.8A
System Parameters		
Features & protection	Anti-islanding protection, DC reverse polarity protection, insulation detection, DC surge protection, AC surge protection, DC short circuit protection, AC overcurrent protection, AC short circuit protection, AC under/over voltage protection, over temperature protection.	
Operating temperature	-30°C~60°C (derate above 45°C)	
Humidity	0%~95%RH, non-condensing	
Altitude	4000m (derate above 2000m)	
Cooling method	Intelligent air cooling	
Noise level	< 70dB	
Communication	ETH/RS485/CAN	
Isolation mode	non-isolated	
Weight	22kg	
Dimensions (W × H × D)	440 × 130 × 600 mm	
IP rating	IP20	

MGS15/30-MH



Exquisite design

Stylish appearance, lightweight design, and easy and flexible operation

Rack - mount design, high space utilization rate, and low operating noise



Powerful performance

Strong load-carrying capacity, supporting 100% unbalanced load

Equipped with VSG function, supporting joint load-carrying with diesel generators



Diverse adaptation

650V~880V wide voltage input range

Supports five modules in parallel with on-grid and off-grid



Grid friendly

Built-in lightweight EMS , supports including self-generation and self-consumption , micro-grid and other application scenarios

Typical Application

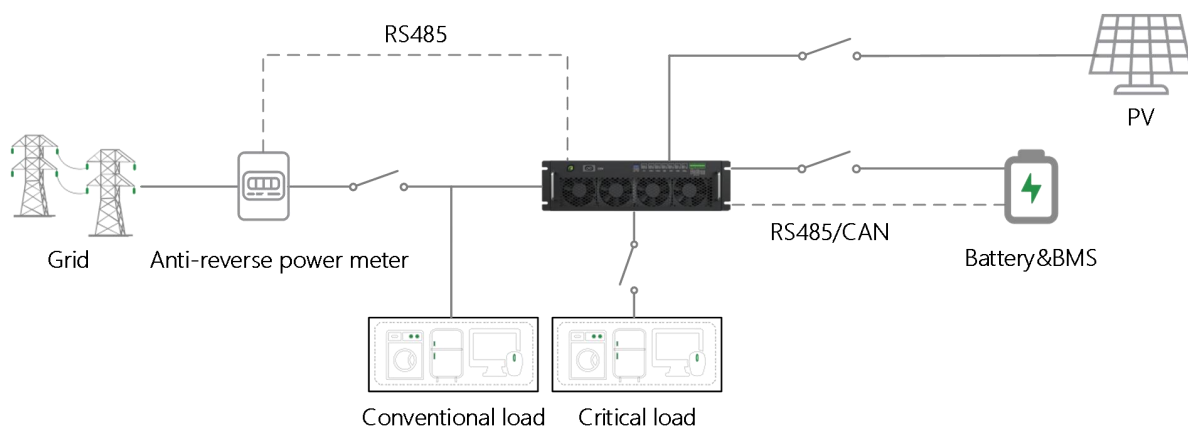

Technical Parameters

Specifications and models	MGS15-MH	MGS30-MH
DC side (battery)		
Battery type	Lithium/lead-acid batteries	
Max charge and discharge power	16.5 kW	33kW
Operating voltage range	650V~880V (3P4W) /615V~880V (3P3W)	
Full load voltage range	680V~880V (3P4W) /615V~880V (3P3W)	

Max discharge current	24A	48A
Max charge current	33A	66A
Number of battery branches	1	
DC side (PV)		
PV max opening voltage	830V*	
MPPT voltage	150V~830V	
MPPT full load voltage range	150V~830V	214V~830V
Number of MPPT	1	
MPPT max current	140A	
AC side (grid)		
Rated output power	15kVA	30kVA
Max output power	16.5kVA	33kVA
Max input power	33kVA	66kVA
Output wire system	3W+PE/3W+N+PE	
Rated output voltage	380/400Vac (-15% ~ +15%)	
Rated frequency	50Hz	
Rated output current	21.7A	43.4A
Max output current	23.9A	47.8A
Max input current	47.8A	95.6A
Total current harmonic distortion	< 3%	
AC side (load)		
Rated output power	15kVA	30kVA
Max output power	16.5kVA	33kVA
Output wire system	3W+PE/3W+N+PE	
Rated output voltage	380/400Vac (-15% ~ +15%)	
Rated frequency	50Hz	
Rated output current	21.7A	43.4A
Max output current	23.9A	47.8A
System parameters		
Features & Protection	Anti-islanding protection, DC reverse connection protection, insulation detection, DC surge protection, AC surge protection, DC short circuit protection, AC overcurrent protection, AC short circuit protection, AC undervoltage and overvoltage protection, over temperature protection	
Operating temperature	-30°C ~ 60°C (>45°C derated use)	
Operating humidity	0% ~ 95%RH, no condensation	
Altitude	4000m (> 2000m derated use)	
Cooling method	Intelligent air cooling	
Noise	< 65dB	
Communications	ETH/RS485/CAN	
Isolation method	Non-isolated	
Weight	22kg	
Dimensions (W x H x D)	440 × 130 × 600 mm	
IP level	IP20	

MGS29.9/30/50/60-M

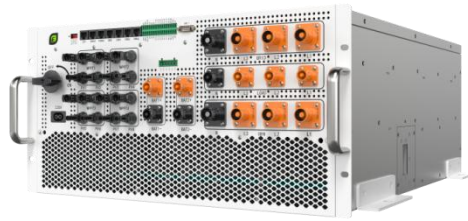

Multiple access

Photovoltaic-storage DC coupling, enabling connection of 8 photovoltaic circuits
 Supports diesel generator access to expand power supply options

Versatile modes

Multiple operational modes including peakshaving, self-consumption, and battery priority
 Excellent multi-unit parallel capability

Reliable power supply

Seamless on/off-grid switching to ensure load stability
 Supports 100% unbalanced load

Integrated efficiency

Compact size with high power density
 Interoperability with BMS, EMS, and fire protection systems

Typical Application

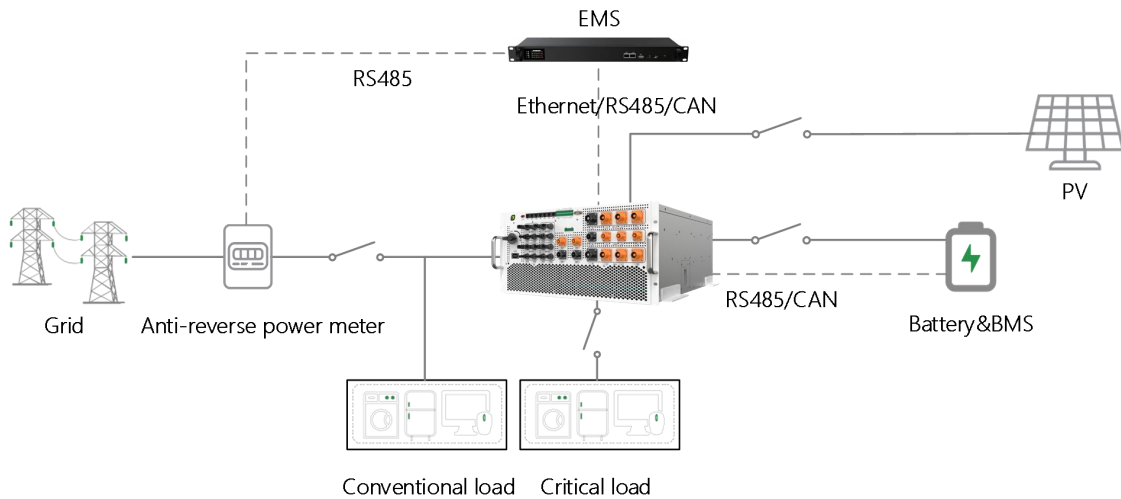

Technical Parameters

Spec*	MGS29.9 -M	MGS30-M	MGS50-M	MGS60-M
Input (PV)				
Maximum input power	59.8 kW	60kW	108kW	108kW
PV maximum opening voltage	1000V			

MPPT operating voltage range	150V~900V			
Maximum DC input current	40+40+40+40A			
Maximum PV short circuit current	60+60+60+60A			
Number of MPPT	4			
MPPT groups number per circuit	2			
Input (battery)				
Battery type	Lithium batteries			
Maximum charge power	32.1 kW	33kW	55kW	66kW
Maximum discharge power	32.1 kW	33kW	55kW	66kW
Operating voltage range	150V~800V			
Maximum charge current	Single circuit current: ≤50A;		Single circuit current: ≤80A;	
Maximum discharge current	Two-circuit total current: ≤100A		Two-circuit total current: ≤160A	
AC side				
Power grid connection	3P4W			
Rated output voltage	220V/380V, 230V/400V			
Rated output power	29.9kW	30kW	50kW	60kW
Maximum output power	29.9kVA	33kVA	55kVA	66kVA
Rated grid frequency	50/60Hz±5Hz			
Rated grid output current	43.2A/45.4A	43.3A/45.6A	72.2A/76A	86.6A/91.2A
Maximum output current	43.2A/45.4A	47.6A/50.1A	79.4A/83.6A	95.3A/100.3A
THDi (@ rated power)	<3% (linear load < 1.5%)			
Overload capacity	110% long term			
Power factor	0.8 leading ~ 0.8 lagging			
System parameters				
Features & Protection	Anti-islanding protection, DC reverse connection protection, insulation detection, DC surge protection, AC surge protection, DC short circuit protection, AC overcurrent protection, AC short circuit protection, AC underovoltage protection, photovoltaic arc protection, leakage protection, battery overcurrent protection, over-temperature protection			
Maximum efficiency	98%			
Operating temperature	-40°C ~ 60°C (> 45°C derated use)			
Operating humidity	0%~95%RH			
Altitude	4000m (> 2000m derated use)			
Cooling method	Intelligent air cooling			
Means of communication	Ethernet /RS485/CAN/4G (optional) /WiFi (optional)			
Weight	65kg			
Dimensions (W x H x D)	520 × 270 × 700mm			
IP grade	IP20			
Protection level	I			
Overvoltage rating	II (DC side), III (AC side)			

* Product parameter specifications are updated from time to time without notice.

MG100/125-M(H)(S)



High-efficiency output

3P4W output, capable of off-grid operation with load without the need for a transformer
Flexible configuration of DC-side capacity and connection types to meet diverse needs

Flexible application

Modular design for flexible on-demand configuration and high online availability
Supports multi-cabinet parallel operation

Safe and reliable

Integrated circuit breakers for all system units to ensure safety
High protection rating of IP55, allowing direct outdoor installation.

Intelligent control

Supports VSG mode to ensure friendliness to diesel generators and grid-forming
Integrate EMS, supports gen and grid connection, compatible with various controls, linkable with BMS and fire systems.

Typical Application

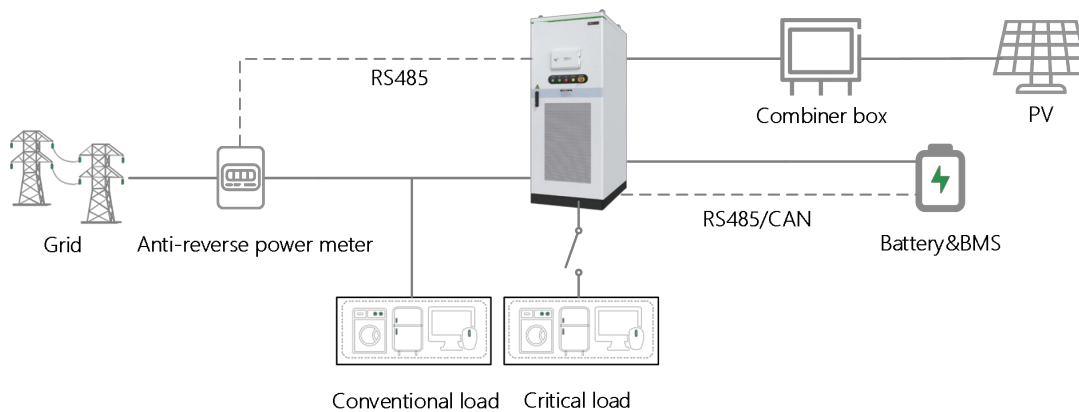

Technical Parameters

Spec.	MG100-M(S)	MG100-MH(S)	MG125-M(S)	MG125-MH(S)
Input(PV)				
PV max. opening voltage	900V			
MPPT operating voltage range	180V ~ 800V			
Number of MPPTs	2	2(1~4optional, default 2)	2	2(1~4optional, default 2)

Max. input power	50kW*2	50kW*2(default)	50kW*2	50kW*2(default)
Input(Battery)				
Battery type	Lithium / lead-acid battery			
Max. charging power	110kW	150kW	110kW	187.5kW
Max. discharging power	110kW	110kW	110kW	137.5kW
Operating voltage range	250V ~ 820V	680V ~ 950V	250V ~ 820V	680V ~ 950V
Max. charging current	200A	225A	200A	225A
Max. discharging current	200A	178A	200A	224A
AC side (On-grid)				
Grid connection	Three-phase Three-wire / Three-phase Four-wire			
Rated output power	100kVA		125kVA	
Max. output power	110kVA		137.5kVA	
Max. grid input power	200kVA		250kVA	
Rated grid frequency	50/60Hz			
Max. input current	288A		360A	
Max. output current	158A		198A	
Overload capability	110% long term			
Power factor	0.99/-1~1			
THDi	<3%			
Load side (Off-grid)				
Rated output power	100kVA		125kVA	
Recommended max. load power	70kVA		88kVA	
Max. output power	110kVA		137.5kVA	
Max. output current	158A		198A	
Max. output voltage	400V			
Rated output frequency	50/60Hz			
THDu (@linear load)	< 3%			
General parameters				
Features & protection	Anti-islanding protection, DC reverse polarity protection, insulation detection, DC surge protection, AC surge protection, DC short circuit protection, AC overcurrent protection, AC short circuit protection, AC under/over voltage protection, and residual current detection			
Operating temperature	-30°C~60°C (derate above 45°C)			
Operating humidity	5%~95%RH, non-condensing			
Altitude	4000m (derate above 2000m)			
Cooling method	Intelligent air cooling			
Communication	Ethernet/4G/RS485/CAN			
Weight	< 500kg			
Dimensions (W*H*D)	800 × 2000 × 1100mm			
IP rating	IP20/IP55			
Safety rating	I			
Overvoltage level	II (DC side) , III (AC side)			

*For the EMGS100/125-MS model, the photovoltaic open-circuit voltage shall be $\leq 900V$; for the EMGS100/125-MHS model, the photovoltaic open-circuit voltage shall be \leq the battery's minimum voltage + 30V.

MG250-MH(S)



Exquisite design

Modular design, convenient maintenance, high online rate of the system

Flexible configuration of battery 1/2 branch, suitable for 0.25C-1C battery scheme



Reliable power supply

650V~880V wide voltage input range

Supports five modules in parallel with on-grid or off-grid



Versatile modes

PQ/VF/VSG multi-mode seamless switching, suitable for a variety of complex scenes

Combined with STS confluence and cabinet system to achieve 20ms seamless access to power grid fuel generation



Configure flexibly

3P3W/3P4W output, without transformer off-grid load

Built-in local controller to achieve local collaborative management of PV, battery and PCS

Typical Application

① AC side parallel grid-forming on/off-grid switching scheme

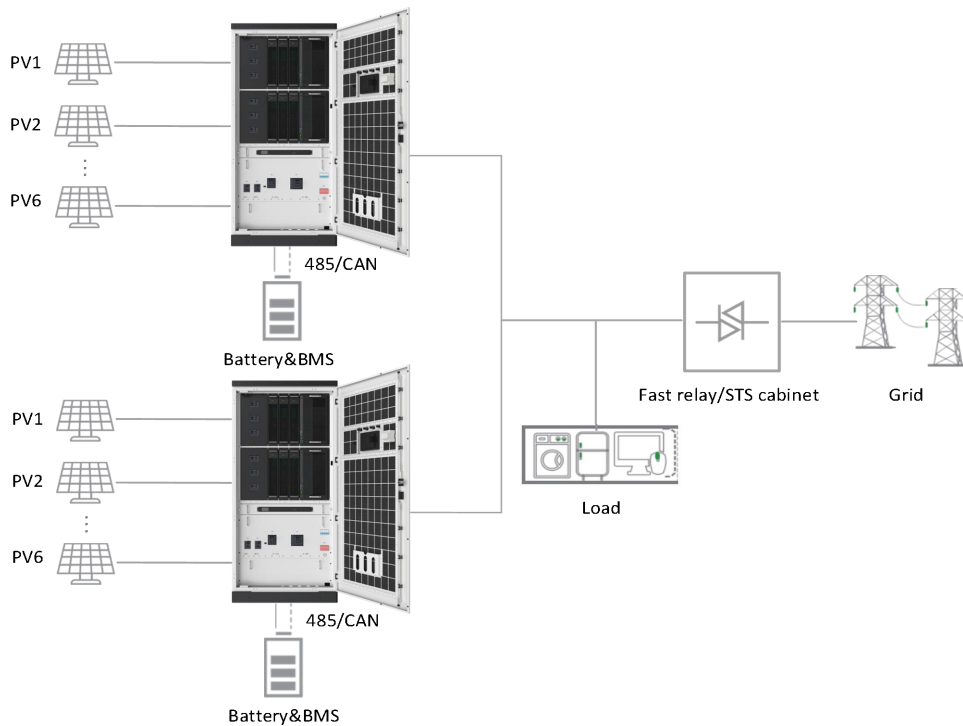

Multiple cabinets are connected to the external fast relay /STS cabinet, allowing loads to be combined. A maximum of 4 cabinets can be connected, with a switching time of 20ms.

② Single-unit load sharing on/off-grid switching scheme

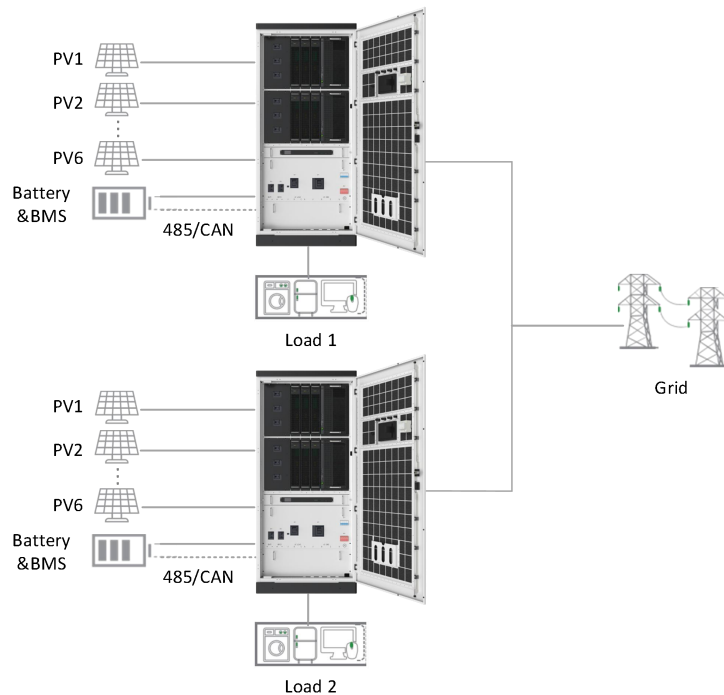

For the scenario where the load unit is less than 250K, the divisible load is connected to the system without STS, and the 20ms on/off-grid switching is carried out through the fast opening device.

Technical parameters

Specifications and Models	MGS250-MH(S)
Input (PV)	
Maximum PV opening voltage	900V
MPPT operating voltage range	180V~800V
Quantity of MPPT	6(2 to 6 is optional, the default is 6)
Rated input power	63kW*6(default)
Maximum input power	69.3kW*6(default)
Input (battery)	
Battery type	Lithium/lead acid batteries
Maximum charging power	415kW
Maximum discharge power	275kW
Operating voltage range	615V~950V(3P3W) /650V~950V (3P4W)
Maximum charging current	610A
Maximum discharge current	404A
AC side	
Grid connection	3P3W/3P4W
On/ off-grid switching time	20ms
Rated voltage	400V
Rated power	250kVA
Maximum power	275kVA
Rated grid frequency	50/60Hz
Rated current	361A
Maximum current	397A
Overload capacity	110% long term
Power factor	0.99/-1 ~ 1
On-grid THDi	<3%
Off-grid THDu(@linear load)	<3%
System parameters	
Features & Protection	Anti-islanding protection, DC reverse connection protection, insulation detection, DC surge protection, AC surge protection, DC short circuit protection, AC overcurrent protection, AC short circuit protection, AC undervoltage and overvoltage protection, residual current detection
Operating temperature	-30 ° C ~ 60 ° C (>50 ° C derated use)
Operating humidity	5%~95%RH, no condensation
Altitude	4000m (> 2000m derated use)
Cooling method	Intelligent air cooling
Communication method	Ethernet /4G/RS485/CAN
Weight	<650kg
Dimensions (W x H x D)	900×2000×900mm
IP level	IP20
Protection level	I
Overvoltage levels	II (DC side), III (AC side)

MGS500-MH(S)



Exquisite design

Modular design, convenient maintenance, high online rate of the system

Flexible configuration of battery 1/2 branch, suitable for 0.25C-1C battery scheme



Reliable power supply

650V~880V wide voltage input range

Supports five modules in parallel with on-grid or off-grid



Versatile modes

PQ/VF/VSG multi-mode seamless switching, suitable for a variety of complex scenes

Combined with STS confluence and cabinet system to achieve 20ms seamless access to power grid fuel generation



Configure flexibly

3P3W/3P4W output, without transformer off-grid load

Built-in local controller to achieve local collaborative management of PV, battery and PCS

Typical Applications

① AC-side parallel grid-forming on/off-grid switching scheme

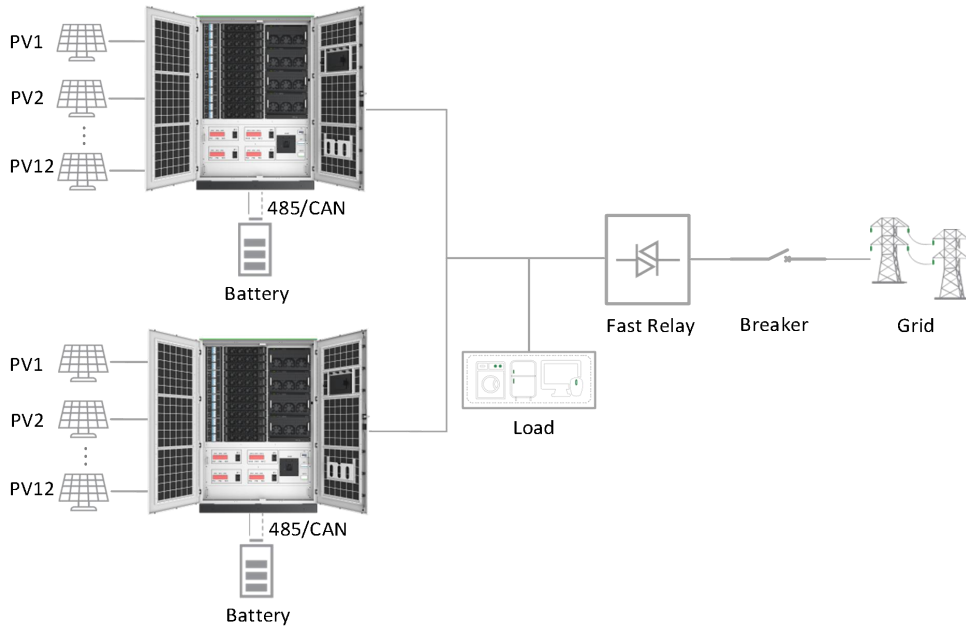

Two cabinets are connected in parallel to an external fast relay, allowing loads confluence with a switching time of 20ms.

② Single-unit load sharing on/off-grid switching scheme

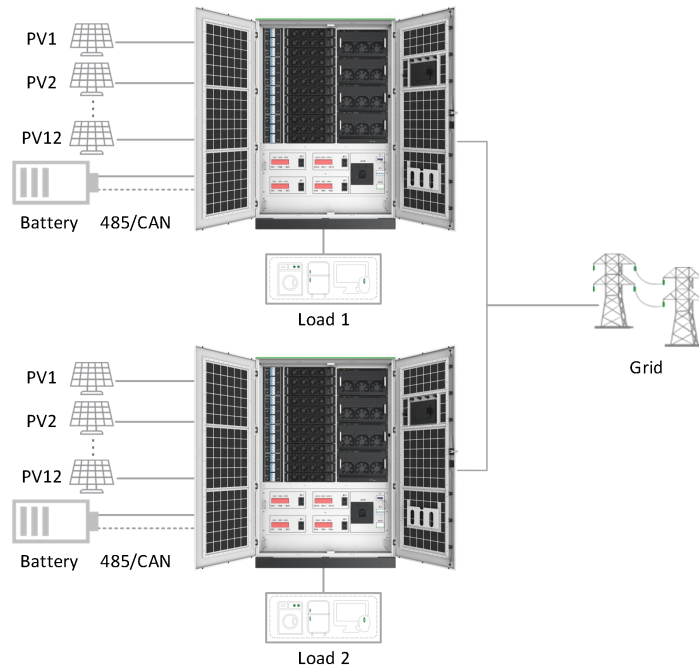

For scenarios with load units below 500kW, loads can be separately connected to the system without requiring STS. A 20ms on-grid/off-grid switching is achieved through build-in fast relay.

Technical Parameters

Specification and model(*)	MG5500-MH(S)
Input (Photovoltaic)	
PV maximum opening voltage	900V
MPPT operating voltage range	180V ~ 800V
Number of MPPT	12(1 ~ 12 optional, default 12)
Rated input power	63kW*12(default)
Maximum input power	69.3kW*12(default)
Input (Battery)	
Battery type	Lithium battery/lead-acid battery
Maximum charge power	831kW
Maximum discharge power	550kW
Operating voltage range	615V ~ 950V(3P3W)/650V ~ 950V(3P4W)
Maximum charge current	1222A
Maximum discharge current	808A
AC side	
Grid connection	3P3W/3P4W
Rated voltage	400V
Rated power	500kVA
Maximum power	550kVA
Rated grid frequency	50/60Hz
Rated current	721A
Maximum current	793A
Overload capacity	110% Long-term
Power factor	0.99/-1~1
On-grid THDi	<3%
Off-grid THDu (@Linear load)	< 3%
System parameters	
Features & Protection	Anti-islanding protection, DC reverse connection protection, insulation detection, DC surge protection, AC surge protection, DC short circuit protection, AC overcurrent protection, AC short circuit protection, AC undervoltage and overvoltage protection, residual current detection
Operating temperature	-30 °C ~ 60 °C (> 50 °C derated use)
Operating humidity	5% ~ 95%RH, no condensation
Altitude	4000m (> 2000m derated use)
Cooling method	Intelligent air cooling
Communication method	Ethernet /4G/RS485/CAN
Weight	900kg
Dimensions (W × H × D)	1300×2000×1000mm
IP level	IP20/IP54
Protection level	I
Overvoltage levels	II (DC side), III (AC side)

PCS125/150/215/250-AM-HX



Efficient and stable

Three-level topology, high conversion efficiency, good power quality

Device derating design, good stability, long equipment life

Flexible deployment

Modular design, smooth expansion, strong scalability

Support multi-machine parallel, can be extended to MW level

String management

Cluster-level battery management, cluster-level battery optimization

Longer system life, highly competitive levelized cost of energy (LCOE)

Grid friendly

Support ms-level scheduling response, active network construction

Support high and low voltage ride-through, proactively adapt to weak power grids

Typical Application

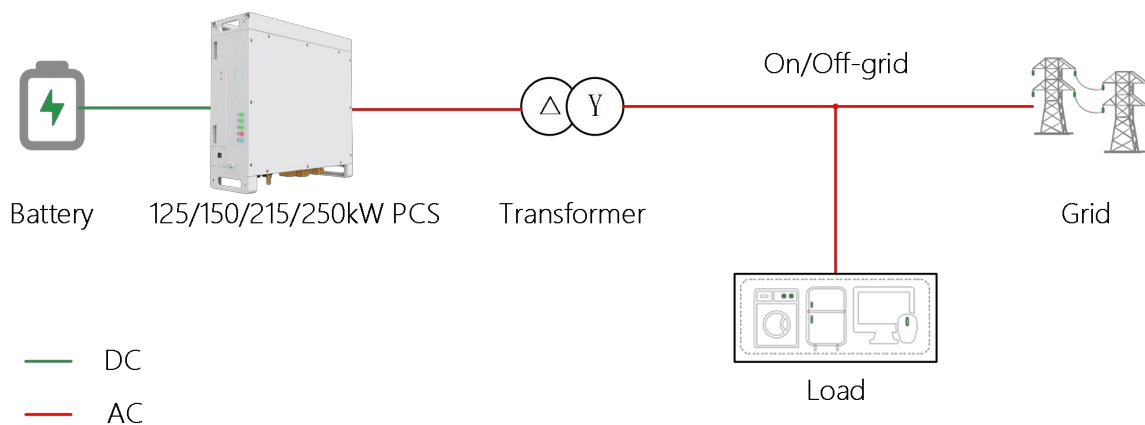

Technical Parameters

Spec.(*)	PCS125-AM-HX	PCS150-AM-HX	PCS215-AM-HX	PCS250-AM-HX
DC side				
Full load charge operating voltage range	600V~1500V	725V~1500V	1000V~1500V	1150V~1500V
Full load discharge operating voltage range	615V~1200V	730V~1500V	1060V~1500V	1200V~1500V
Max current	245A	245A	245A	245A
Max charge/discharge power	137.5kW	165kW	237kW	275kW
AC side				
Rated voltage	400V	480V	690V	800V
Rated voltage range	-15%~+10%			
Wiring method	3P3W			
Rated power	125kW	150kW	215kW	250kW
Maximum power	137.5kW	165kW	237kW	275kW
Rated current	180A	180A	180A	180A
Maximum current	198A	198A	198A	198A
Frequency range	50±5Hz/60Hz±5Hz			
Power factor	0.99/-1~1			
Current distortion rate	<3% (@rated power)			
Overload capacity	110% long term			
Power factor	97.6%	97.8%	99%	99%
Protection characteristics				
Protection function	AC over-current protection, AC over-voltage protection, AC short-circuit protection, DC surge protection, DC over-current protection, DC over-voltage protection, over-temperature protection, etc.			
General parameters				
Dimensions (W x H x D)	275 × 845 × 810mm			
Weight	108kg			
Altitude	4000m (> 3000m derated use)			
Operating temperature	-30°C ~ 60°C (> 50°C derated use)			
Storage temperature	-40°C ~ 70°C			
Humidity	0%RH~100%RH, no condensation			
Cooling method	Intelligent air cooling			
IP grade	IP66			
Communication method	CAN/RS485/ Ethernet/Bluetooth/4G			
Communication protocol	IEC61850, CAN2.0B, Modbus TCP/RTU			

PCS1250/1500-ASH



Efficient and stable

Integrated cabinet design with high protection
With complete protection functions and strong anti-interference capability

Flexible deployment

Integrated cabinet design makes operation more convenient
Supports multi-unit parallel connection and scalable to MW level

String management

Cluster-level battery management, cluster-level battery optimization
Longer system life, highly competitive levelized cost of energy (LCOE)

Grid friendly

Support ms-level scheduling response, active network construction
Support high and low voltage ride-through, proactively adapt to weak power grids

Typical Application

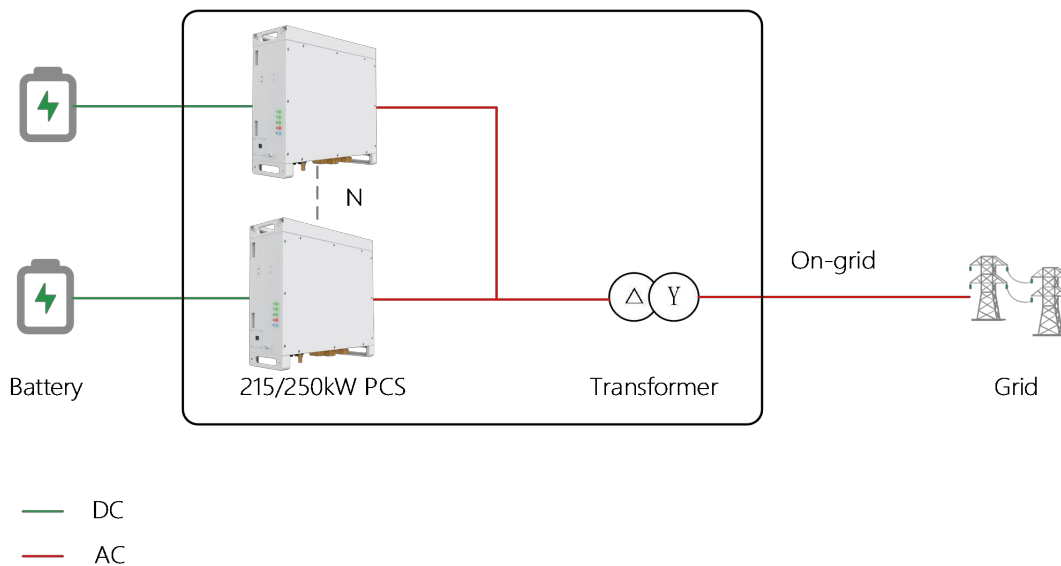

Technical Parameters

Spec.	PCS1500-ASH
DC side	
Max. charging power	1500kW
Max. discharging power	1650kW
Operating voltage range	1200V~1500V(full load: 1215V-1500V)
Max. current	1470A
AC side	
Rated voltage	800V
Voltage range	-15% ~ +10%
Wiring method	Three-phase Three-wire
Rated power	1500kW
Max. power	1650kW
Rated current	1080A
Max. current	1188A
Rated frequency	50/60Hz
Power factor	0.99/-1 ~ 1
Current distortion rate	< 3%(@rated power)
Overload capacity	110% long term
Max. efficiency	99%
Protection characteristics	
Protection functions	AC overcurrent protection, AC overvoltage protection, AC short circuit protection, DC surge protection, DC overcurrent protection, DC overvoltage protection, overtemperature protection, etc.
General parameters	
Dimension (W × H × D)	1900*2250*850mm
Weight	1300kg
Altitude	4000m (derate above 3000m)
Operating temperature	-30°C~60°C (derate above 50 °C)
Storage temperature	-40°C~70°C
Humidity	0%RH ~ 100%RH, non-condensing
Cooling method	Intelligent air cooling
IP rating	IP55
Communication	CAN / RS485 / Ethernet / Bluetooth / 4G
Communication protocol	IEC61850, CAN2.0B, Modbus TCP/RTU

PCS2500/5000-AF



Efficient and stable

Integrated cabinet design, highly protected
Equipped with complete protection
Complete protection functions, strong anti-interference ability

Flexible deployment

Integrated cabinet design makes operation more convenient
Modular design, minimal installation, minimalist operation and maintenance

String management

Cluster-level battery management, cluster-level battery optimization
Longer system life, highly competitive leveled cost of energy (LCOE)

Grid friendly

Support ms-level scheduling response, active network construction
Support high and low voltage ride-through, proactively adapt to weak power grids

Typical Application

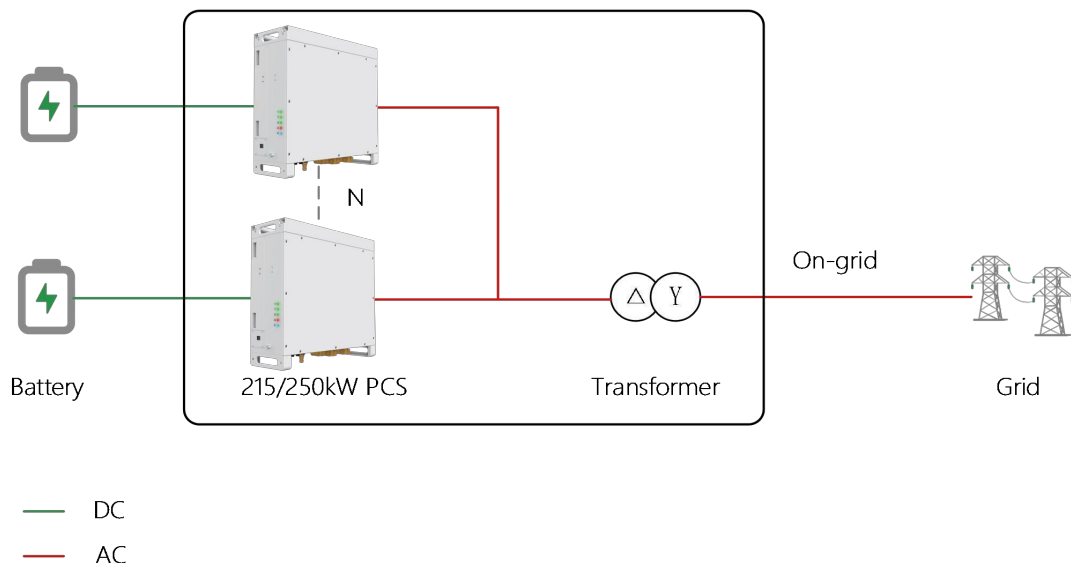

Technical Parameters

Spec.	PCS2500-AST	PCS5000-AST
DC side		
Full-load charge voltage range	1000V~1500V	
Full-load discharge voltage range	1060V~1500V	
Max. current	2940A	5880A
Max charge/discharge power	2750kW	5500kW
AC side		
Rated voltage	690V	
Voltage range	-15% ~ +10%	
Wiring method	Three-phase Three-wire	
Rated power	2500kW	5000kW
Max. power	2750kW	5500kW
Rated current	2160A	4320A
Max. current	2376A	4752A
Rated frequency	50/60Hz	
Power factor	0.99/-1 ~ 1	
Current distortion rate	< 3% (@rated power)	
Overload capacity	110% long term	
Max. efficiency	99%	
Protection characteristics		
Protection functions	AC overcurrent protection, AC overvoltage protection, AC short circuit protection, DC surge protection, DC overcurrent protection, DC overvoltage protection, over-temperature protection, etc	
General parameters		
Dimensions (W × H × D)	5×2.25×2.438m	6×2.25×2.438m
Weight	15.5t	18t
Altitude	4000m (derate above 3000m)	
Operating temperature	-30°C~60°C (derate above 50°C)	
Storage temperature	-40°C~70°C	
Humidity	0%RH ~ 100%RH, non-condensing	
Cooling method	Intelligent air cooling	
IP rating	IP55	
Communication	CAN/RS485/Ethernet/Bluetooth/4G	
Communication protocol	IEC61850, CAN2.0B, Modbus TCP/RTU	

*Dimensions and weight subject to actual product.



The information in this document is for reference only. Please refer to the product's accompanying information for specific parameters. CONSNANT reserves the right to change the technical parameters due to product upgrades and product customization, and therefore changes in the technical data will occur without prior notice.



Shenzhen Consnant Technology Co., Ltd.
Building B6, Junfeng Industrial Park, Yonghe Road, Fuhai Sub-District,
Bao'an District, Shenzhen City, 518103 P.R.China

🌐 www.consnant.com
☎ 0086-755-29772323
📠 0086-755-29772626